

OUTDOOR program



CLADDING specification



WPC SISTEMI

Priroda u izvrsnoj formi

WPC good choice

Composite cladding panels with a polymer shell. This composite wall cladding is beautiful, colorfast, easy to clean and maintain, and is one of the best alternatives to traditional wood exterior cladding.

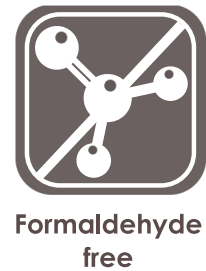
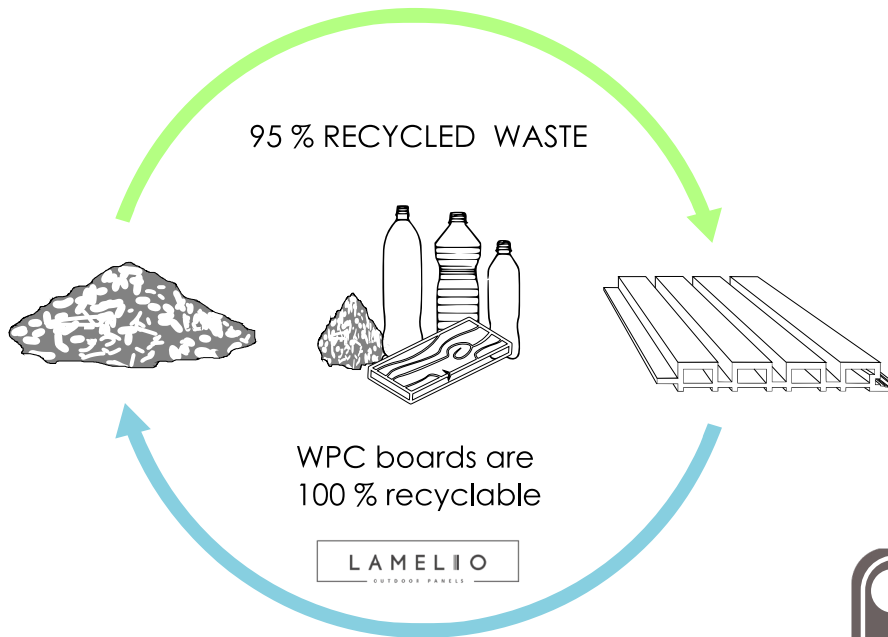

ECO friendly

WPC is green and eco-friendly with wide applications which can replace wood material (low maintenance cost and having over 15 to 25 years' service life). The products have passed ISO 9000, the quality management system, ISO 14001, the environmental management system and OHSAS18001, the occupational health and safety management system certification. The company's products have obtained FSC certification and passed the REACH test. The products have been tested in ITS and SCS for a long time and passed the corresponding standards.



Weather resistant

As a product for outdoor use, we place high demands on the performance of the product. Our wood-plastic products are designed for extreme weather, such as extreme temperatures, high humidity and insect resistance, etc.



Weather resistant



Insect resistant



Waterproof

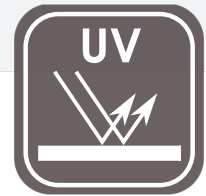

UV resistant

Warranty against Stain and fade

Our products are tested for the influence of the weather, where we achieve excellent results by default.

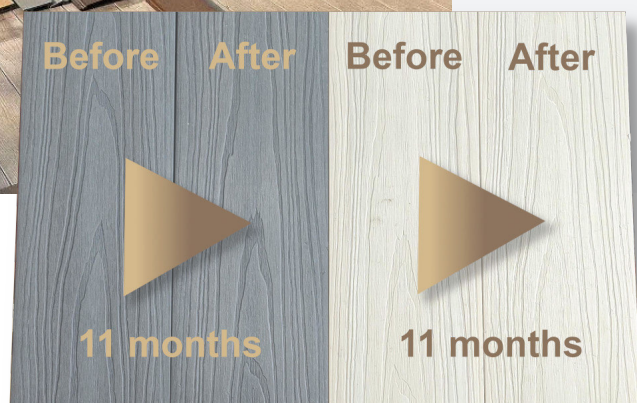
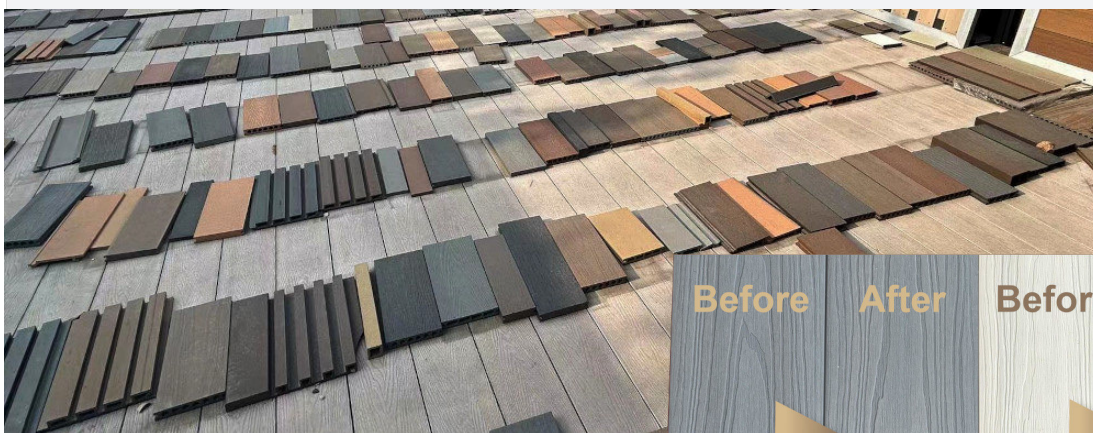

Unique colors and an interesting surface

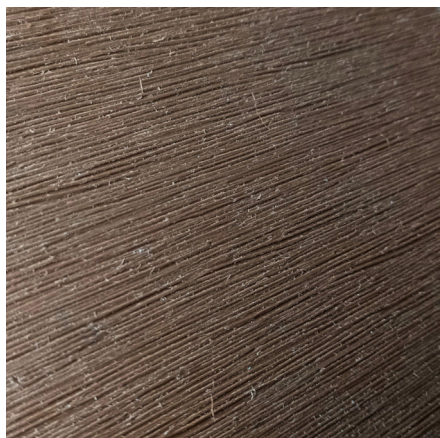

Our panels are characterized by a unique surface that faithfully imitates the surface of wood. We chose the colors so that they reflect the unique character of your buildings.

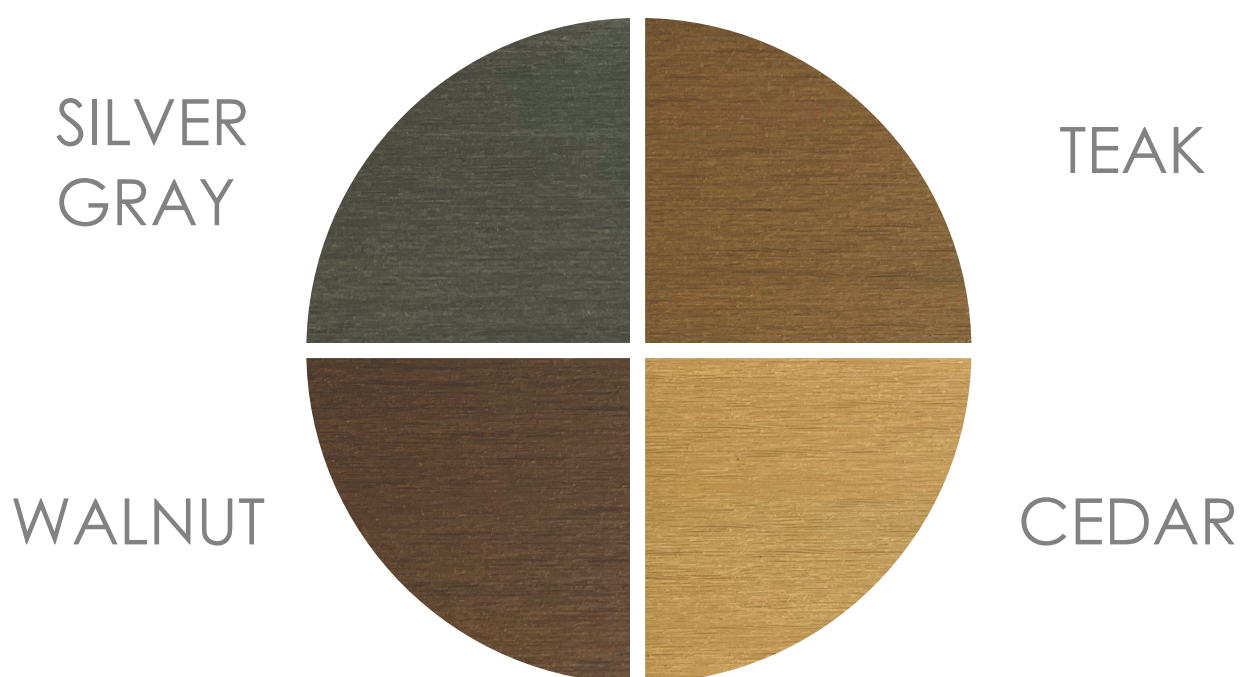

Easy installation

The installation of cladding panels is very simple. By gradually placing the panels next to each other, you will achieve a very nice appearance of your house in the end.



Easy instalation



WPC SISTEMI
Priroda u izvrsnoj formi

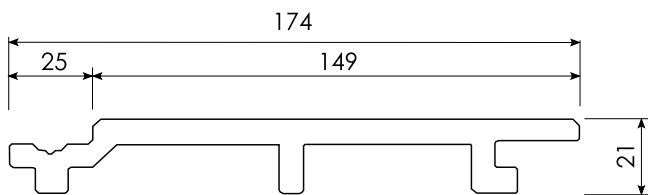

Panel CARLOS



Usable surface per board	0,432 m ²
Mass per unit area	11,8 kg/m ²
Outer width	174 mm
Usable width	149 mm
Standard lenght	2 900 mm



panel corner universal
41 x 53 mm x 2,90 m

item PA5933 |  Teak
item PA5934 |  Walnut

item PA5935 |  Cedar
item PA5936 |  Silver Gray

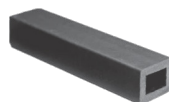

panel underlay WPC black
40 x 30 mm x 2,90 m

item PA5932 |  Black

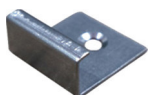

starting clip
24 x 28 x 4 mm

Product description:

	Nominal values
Type of product	Wood-plastic composite (WPC) cladding. The core of the wood-plastic composite consists of 60% wood and 40% high-density polyethylene (HDPE) fillers + additives. The core is covered with a coextruded plastic cap layer. The profile has got a tongue- and groove connection.
Manufacturer	GAUDIAHOME, s.r.o
Ratio wood/ HDPE	35 % Plastic, 60 % Wood fiber, 5 % Additives
Item No.	PA5919, PA5920, PA5921, PA5922
Item Name	PANEL CARLOS TEAK, PANEL CARLOS CEDAR, PANEL CARLOS SILVER GRAY, PANEL CARLOS WALNUT
Profiling/ shape	The technical drawing is visible in Figure 1
Profile width (mm)	174
Total thickness (mm)	21
<i>Thickness core</i>	6 - 7
<i>Thickness coextruded layer (cap)</i>	0.5
Density(g/m ³)	1.35
Color	Teak, Cedar Silver Gray, Walnut
Surface structure	
Lenght (mm)	2 900

Figure 1: Profile of the material

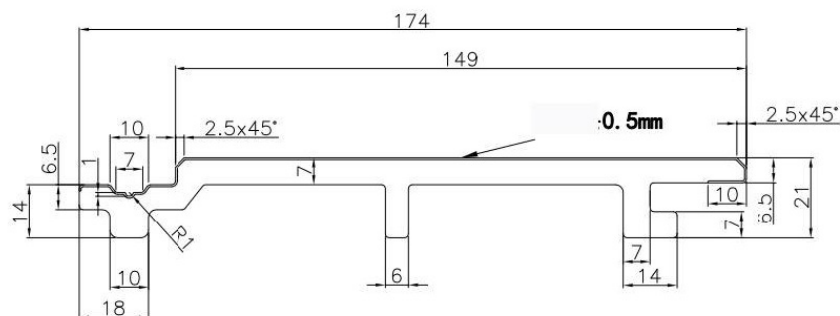



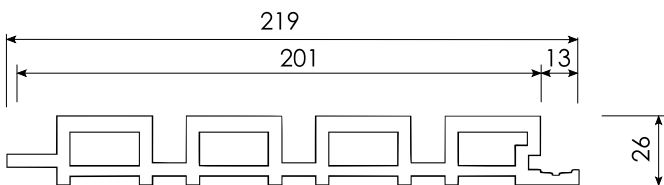
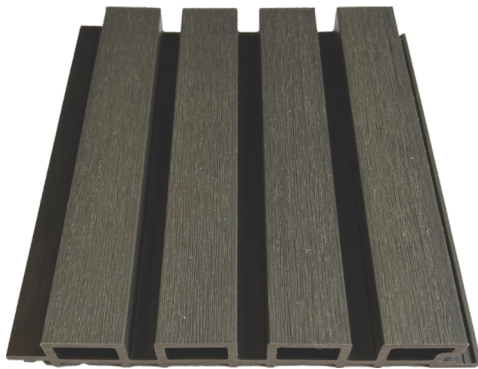
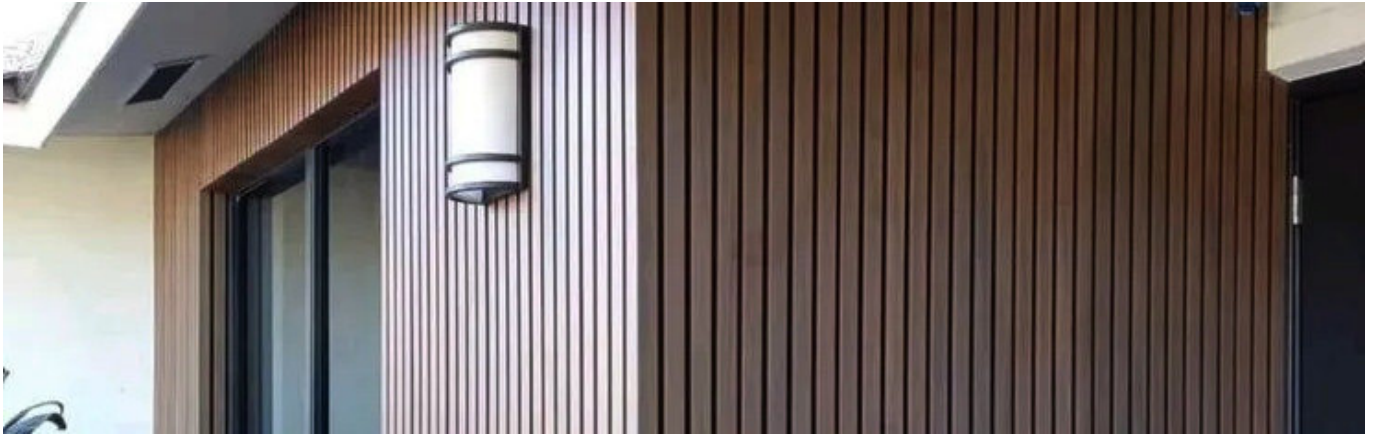

Test	Standard / Method	Value	Verdit
Physical Properties			
Moisture Content	EN15534 EN322	0.85%	
Mechanical Properties			
Falling Mass Impact Resistance	EN15534	Max Crack length(mm): No crack. Max Residual Indentation(mm): 0.13	Pass
Brinell Hardness	EN15534	83Mpa	
Resistance to Indentation	EN15534	Rate of elastic recovery: 73%	
Bond Strength	EN319	Average Bond Strength>1.78MPa No obvious abruption and damage after test	
Thermal Properties			
Coefficient of Linear Thermal Expansion	EN15534	$41.6 \times 10^{-6} K^{-1}$	$\leq 50 \times 10^{-6} K^{-1}$ Pass
Heat Build-up	EN15534	$\Delta T = -2.9^{\circ}C$	
Durability			
Resistance to Artificial Weathering	EN15534	No blistering, cracking or peeling observed	
Swelling and Water Absorption (28days immersion)	EN15534	Swelling: 0.89% in thickness, 0.07% in width, 0.07% in length.	Swelling $\leq 4\%$ in thickness $\leq 0.8\%$ in width $\leq 0.4\%$ in length Pass
		Water absorption: Max $\leq 1.09\%$	Water absorption: Max. $\leq 9\%$ Pass
Resistance to Boiling Water	EN15534	Mean: 0.95%	Mean $\leq 7\%$ Pass
		Max : 1%	Max. $\leq 9\%$ Pass
Mould Resistance	EN15534	Rating 0, no growth	
Fire			
Euroclass	EN13501	E	
Safety & Environment Protection			
Heavy Metal Content	EPA3051	Sb:ND, As:ND, Se:ND, Sn:ND	
Lead Content Test	EUNo.628/2015	Non Detected	
Pb, Cd, Hg, Cr6+	RoHs- IEC62321	Pb:ND, Cd:ND, Hg:ND, Cr6+:ND	

Panel BRUNO

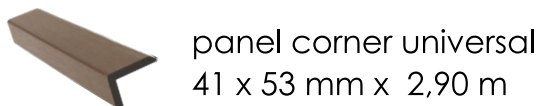





Usable surface per board	0,58 m ²
Mass per unit area	10,95 kg/m ²
Outer width	219 mm
Usable width	201 mm
Standard lenght	2 900 mm







- | | |
|--|---|
| item PA5933  Teak | item PA5935  Cedar |
| item PA5934  Walnut | item PA5936  Silver Gray |







- | | |
|--|---|
| item PA5937  Teak | item PA5939  Cedar |
| item PA5938  Walnut | item PA5940  Silver Gray |



- | | |
|--|---|
| item PA5941  Teak | item PA5943  Cedar |
| item PA5942  Walnut | item PA5944  Silver Gray |



- | | |
|--|---|
| item PA5949  Teak | item PA5951  Cedar |
| item PA5950  Walnut | item PA5952  Silver Gray |

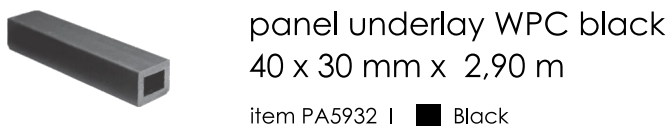

Product description:

	Nominal values
Type of product	Wood- plastic composite (WPC) cladding. The core of the wood- plastic composite consists of 60% wood and 40% high- density polyethylene (HDPE) fillers + additives. The core is covered on all sides with a coextruded plastic cap layer. The profile has got a tongue- and groove connection.
Manufacturer	GAUDIAHOME, s.r.o
Ratio wood/ HDPE	35 % Plastic, 60 % Wood fiber, 5 % Additives
Item No.	PA5927, PA5928, PA5929, PA5930
Item Name	PANEL BRUNO TEAK/CHARCOAL, PANEL BRUNO CEDAR/CHARCOAL, PANEL BRUNO SILVER GRAY/CHARCOAL, PANEL BRUNO WALNUT/CHARCOAL
Profiling/ shape	The technical drawing is visible in Figure 1
Profile width (mm)	219
Total thickness (mm)	26
<i>Thickness core</i>	
<i>Thickness coextruded layer (cap)</i>	0.5
Density(g/m ³)	1.35
Color	Teak, Cedar, Silver Gray, Walnut
Surface structure	
Length (mm)	2 900

Figure 1: Profile of the material

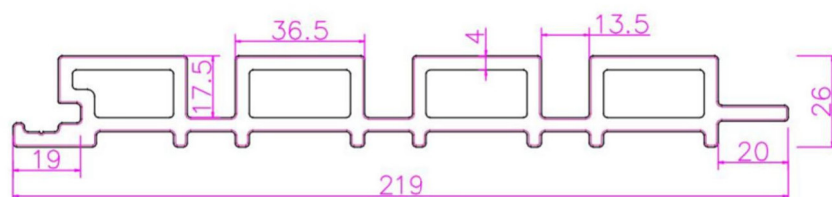

Test	Standard / Method	Value	Verdit
Physical Properties			
Moisture Content	EN15534 EN322	0.85%	
Mechanical Properties			
Falling Mass Impact Resistance	EN15534	Max Crack length(mm): No crack. Max Residual Indentation(mm): 0.13	Pass
Brinell Hardness	EN15534	83Mpa	
Resistance to Indentation	EN15534	Rate of elastic recovery: 73%	
Bond Strength	EN319	Average Bond Strength>1.78MPa No obvious abruption and damage after test	
Thermal Properties			
Coefficient of Linear Thermal Expansion	EN15534	$41.6 \times 10^{-6} \text{ K}^{-1}$	$\leq 50 \times 10^{-6} \text{ K}^{-1}$ Pass
Heat Build-up	EN15534	$\Delta T = 2.9^\circ\text{C}$	
Durability			
Resistance to Artificial Weathering	EN15534	No blistering, cracking or peeling observed	
Swelling and Water Absorption (28days immersion)	EN15534	Swelling: 0.89%in thickness, 0.07%in width, 0.07%in length.	Swelling $\leq 4\%$ in thickness $\leq 0.8\%$ in width $\leq 0.4\%$ in length Pass
		Water absorption: Max $\leq 1.09\%$	Water absorption: Max $\leq 9\%$ Pass
Resistance to Boiling Water	EN15534	Mean: 0.95%	Mean $\leq 7\%$ Pass
		Max : 1%	Max $\leq 9\%$ Pass
Mould Resistance	EN15534	Rating 0, no growth	
Fire			
Euroclass	EN13501	E	
Safety & Environment Protection			
Heavy Metal Content	EPA3051	Sb:ND, As:ND, Se:ND, Sn:ND	
Lead Content Test	EUNo.628/2015	Non Detected	
Pb, Cd, Hg, Cr6+	RoHS-IEC62321	Pb:ND, Cd:ND, Hg:ND, Cr6+:ND	



teak cedar silver gray walnut



PA5923 PA5924 PA5925 PA5926

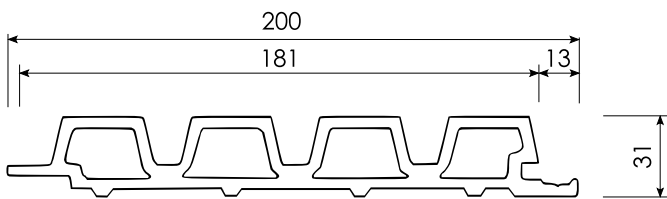

Usable surface per board	0,524 m ²
Mass per unit area	14,9 kg/m ²
Outer width	200 mm
Usable width	181 mm
Standard length	2 900 mm



panel corner universal
41 x 53 mm x 2,90 m

item PA5933 | Teak item PA5935 | Cedar
item PA5934 | Walnut item PA5936 | Silver Gray

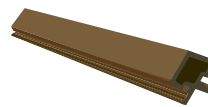

panel corner Leo
49 x 49 mm x 2,90 m

item PA5945 | Teak item PA5947 | Cedar
item PA5946 | Walnut item PA5948 | Silver Gray



panel trim Bruno
26 x 49 mm x 2,90 m

item PA5941 | Teak item PA5943 | Cedar
item PA5942 | Walnut item PA5944 | Silver Gray

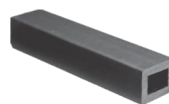

panel underlay WPC black
40 x 30 mm x 2,90 m

item PA5932 | Black

Product description:

Nominal values	
Type of product	Wood-plastic composite (WPC) cladding. The core of the wood-plastic composite consists of 60% wood and 40% high-density polyethylene (HDPE) fillers + additives. The core is covered on all sides with a coextruded plastic cap layer. The profile has got a tongue- and groove connection.
Manufacturer	GAUDIAHOME, s.r.o
Ratio wood/ HDPE	35 % Plastic, 60 % Wood fiber, 5 % Additives
Item No.	PA5923, PA5924, PA5925, PA5926
Item Name	PANEL LEO TEAK, PANEL LEO CEDAR, PANEL LEO SILVER GRAY, PANEL LEO WALNUT
Profiling/ shape	The technical drawing is visible in Figure 1
Profile width (mm)	200
Total thickness (mm)	31
<i>Thickness core</i>	4-4.5
<i>Thickness coextruded layer (cap)</i>	1
Density(g/m ³)	1.35
Color	Teak, Cedar, Silver Gray, Walnut
Surface structure	
Length (mm)	2 900

Figure 1: Profile of the material

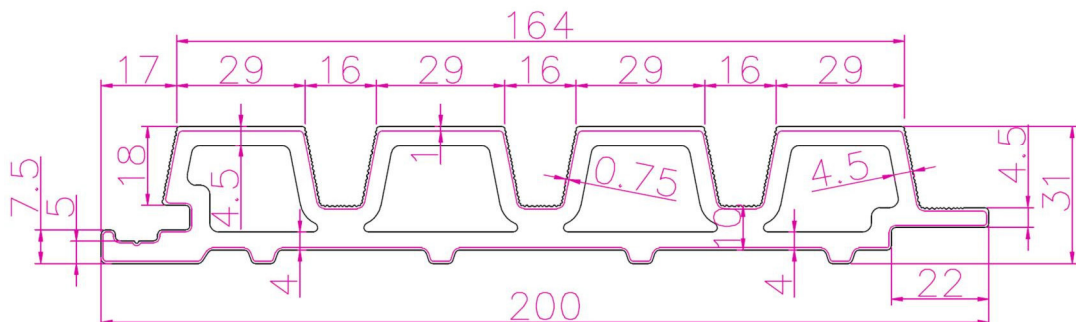

Test	Standard / Method	Value	Verdit
Physical Properties			
Moisture Content	EN15534 EN322	0.85%	
Mechanical Properties			
Falling Mass Impact Resistance	EN15534	Max Crack length(mm): No crack. Max Residual Indentation(mm): 0.13	Pass
Brinell Hardness	EN15534	83Mpa	
Resistance to Indentation	EN15534	Rate of elastic recovery: 73%	
Bond Strength	EN319	Average Bond Strength>1.78MPa No obvious abruption and damage after test	
Thermal Properties			
Coefficient of Linear Thermal Expansion	EN15534	$41.6 \times 10^{-6} K^{-1}$	$\leq 50 \times 10^{-6} K^{-1}$ Pass
Heat Build-up	EN15534	$\Delta T = -2.9^{\circ}C$	
Durability			
Resistance to Artificial Weathering	EN15534	No blistering, cracking or peeling observed	
Swelling and Water Absorption (28days immersion)	EN15534	Swelling: 0.89% in thickness, 0.07% in width, 0.07% in length.	Swelling $\leq 4\%$ in thickness $\leq 0.8\%$ in width $\leq 0.4\%$ in length Pass
		Water absorption: Max $\leq 1.09\%$	Water absorption: Max. $\leq 9\%$ Pass
Resistance to Boiling Water	EN15534	Mean: 0.95%	Mean $\leq 7\%$ Pass
		Max. : 1%	Max. $\leq 9\%$ Pass
Mould Resistance	EN15534	Rating 0, no growth	
Fire			
Euroclass	EN13501	E	
Safety & Environment Protection			
Heavy Metal Content	EPA3051	Sb:ND, As:ND, Se:ND, Sn:ND	
Lead Content Test	EUNo.628/2015	Non Detected	
Pb, Cd, Hg, Cr6+	RoHS- IEC62321	Pb:ND, Cd:ND, Hg:ND, Cr6+:ND	

Assembly - basic attachment

Panel CARLOS

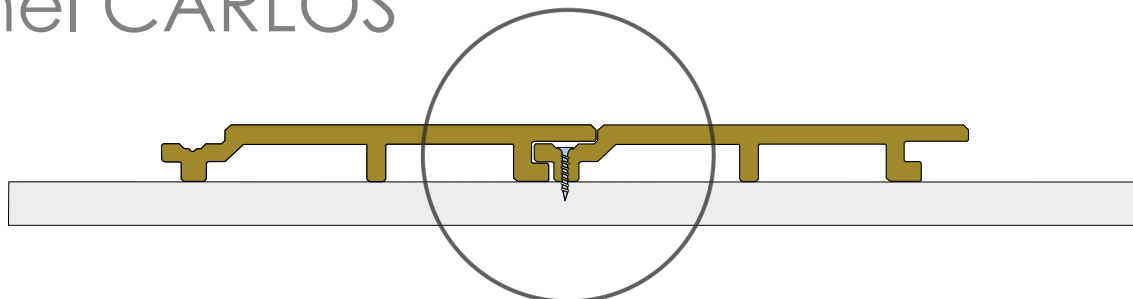

Panel BRUNO

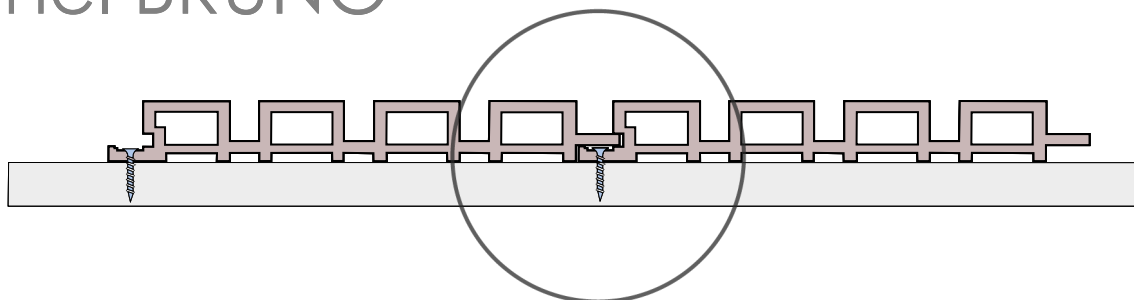

Panel LEO

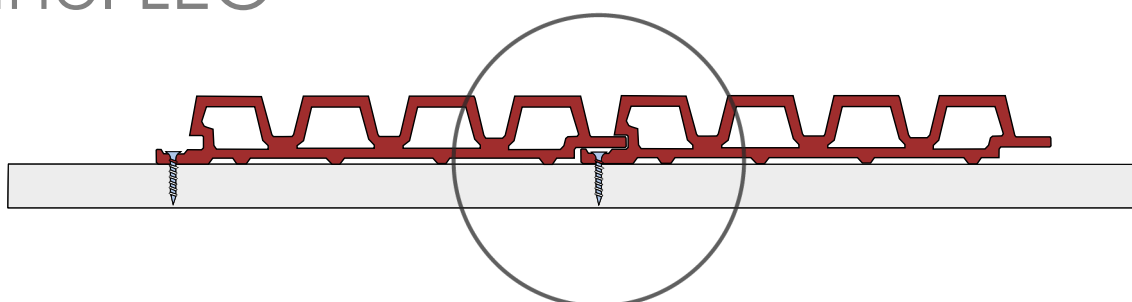

WPC SISTEMI .d.o.o.
*Milivoja Matošeca 4 (dvorišna strana),
Malešnica, 10090 Zagreb, Hrvatska*

*info@wpc-sistemi.hr
www.wpc-sistemi.hr
+385 (0)91 3886 991*